

VN2A P01

Current Sensor

Model Number:

VN2A 25 P01

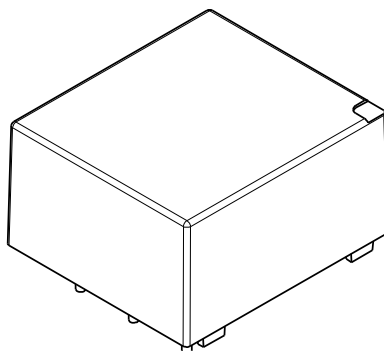

For the electronic measurement of voltage: DC, AC, pulsed..., with galvanic separation between the primary and the secondary circuit.

Features

- ✧ Closed loop (compensated) voltage sensor using the Hall Effect
- ✧ Insulating plastic case recognized according to UL94-V0
- ✧ Single power supply: +24V
- ✧ No insertion loss
- ✧ Small size
- ✧ High accuracy
- ✧ Very good linearity
- ✧ Very low offset drift over temperature
- ✧ High output frequency bandwidth
- ✧ Standards:
 - EN50178: 1997
 - IEC 61010-1: 2000
 - UL 508: 2010

Application Principles

When measuring voltage, it is actually achieved by measuring the current proportional to the measured voltage. Therefore, a suitable measuring resistor R1 must be connected in series at the primary of the voltage sensor during use.

Applications

- ✧ AC variable speed
- ✧ Uninterruptible Power Supplies (UPS)
- ✧ Static converters for DC motor drives
- ✧ Switch Mode Power Supplies (SMPS)
- ✧ Power supplies for welding applications

Safety

This sensor must be used according to IEC 61010-1.

This sensor must be used in electric/electronic equipment with respect to applicable standards and safety requirements in accordance with the manufacture's operating instructions.

Caution, risk of electrical shock!



When operating the sensor, certain parts of the module can carry hazardous voltage (e.g. Primary busbar, power supply). Ignoring this warning can lead to injury and/or cause serious damage.

This sensor is a built-in device, whose conducting parts must be inaccessible after installation. A protective housing or additional shield could be used.

Main supply must be able to be disconnected.

VN2A P01

Absolute maximum ratings(not operating)

Parameter	Symbol	Unit	Value
Supply voltage	V_C	V	±25.2

- ※ Stresses above these ratings may cause permanent damage.
- ※ Exposure to absolute maximum ratings for extended periods may degrade reliability.

Environmental and mechanical characteristics

Parameter	Symbol	Unit	Min	Typ	Max	Comment
Ambient operating temperature	T_A	°C	-40		85	
Ambient storage temperature	T_S	°C	-45		105	
Mass	m	g		23		
Standards	EN 50178, IEC 61010-1, UL 508					

Insulation coordination

Parameter	Symbol	Unit	Value	Comment
Rms voltage for AC insulation test @ 50Hz, 1min	V_d	kV	4.2	
Impulse withstand voltage 1.2/50µs	V_w	kV	16	
Plastic case	-	-	UL94-V0	
Comparative tracking index	CTI	PLC	3	
Clearance (pri.- sec.)	d_{cl}	mm	19.5	
Creepage distance (pri.- sec.)	d_{cp}	mm	19.5	
Application example	-	-	800V CAT III PD2	Reinforced insulation, according to EN 50178, EN 61010-1
Application example	-	-	1600V CAT III PD2	Basic insulation, according to EN 50178, EN 61010-1

Electrical data

※ With $T_A = 25^\circ\text{C}$, $V_C = \pm 24\text{V}$, $R_L = 100\Omega$, unless otherwise noted.

Parameter	Symbol	Unit	Min	Typ	Max	Comment
Primary nominal rms current	I_{PN}	mA	0		5	
Maximum measuring current	I_{PM}	mA	0		7	
Measuring resistance	R_M	Ω	30 30		240 150	@ $\pm 5\text{mA}$ @ $\pm 7\text{mA}$
Output nominal rms current	I_{SN}	mA		25		
Supply voltage	V_C	V		24		@ $\pm 5\%$
Primary coil resistance	R_P	Ω		300		@ 85°C
Secondary coil resistance	R_S	Ω		52		@ 85°C
Coil turn ratio	K_N	-		2500:500		
Current consumption	I_c	mA		$10 + I_S$		
Electrical offset current	I_0	mA		0.05	0.15	
Thermal drift of offset current	I_{OT}	mA		0.15 0.30	0.5 0.8	@ $-25^\circ\text{C} \sim 85^\circ\text{C}$ @ $-40^\circ\text{C} \sim 85^\circ\text{C}$
Sensitivity error	ε_G	%	-0.4		0.4	
Linearity error	ε_L	% of I_{PN}	-0.2		0.2	Exclusive of I_0
Accuracy@ I_{PN}	X	% of I_{PN}	-0.8		0.8	Exclusive of I_0
Response time@ 90% of I_{PN}	t_r	μs		25		

VN2A P01

Dimensions(Unit mm)

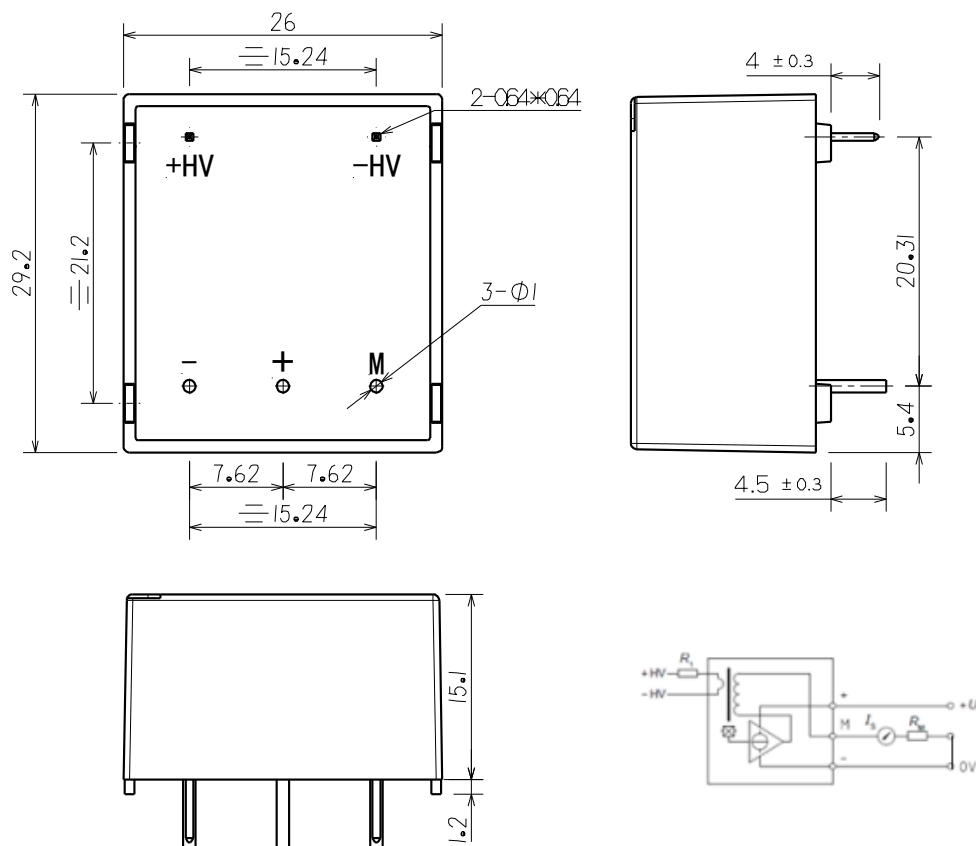

Mechanical characteristic

◇ General tolerance	±0.3 mm
◇ Primary connecting pin	2 pins 0.64×0.64mm
◇ Recommended PCB hole	Φ1.2
◇ Secondary signal connecting pin	3 pins Φ1mm
◇ Recommended PCB hole	Φ1.2

Remarks

- ◇ When the measured voltage V_P is connected to the +HV of the sensor, the output current I_S is in the forward direction.

Instructions for using voltage sensor VN2A 25 P01

Selection of measuring resistance R1: When the sensor operates at the nominal primary current, we got the best measurement accuracy. In practical application, select the appropriate measuring resistor R1 to ensure that the measured current corresponding to the measured voltage works at 5mA.

For example:
 The measured voltage $V_{IN}=250V$

- $R1=50k\Omega$, $I_P=5mA$, at $25^\circ C$ measuring accuracy is 0.8% .
- $R1=100k\Omega$, $I_P=2.5mA$, at $25^\circ C$ measuring accuracy is 1.6%.

Recommended measurement range: Considering the resistance of the primary coil (the coil resistance must be less than the measurement resistance R1) and insulation characteristics, the measurement range of the voltage sensor is from 10V to 1500V.